

# WA350 16t/20t

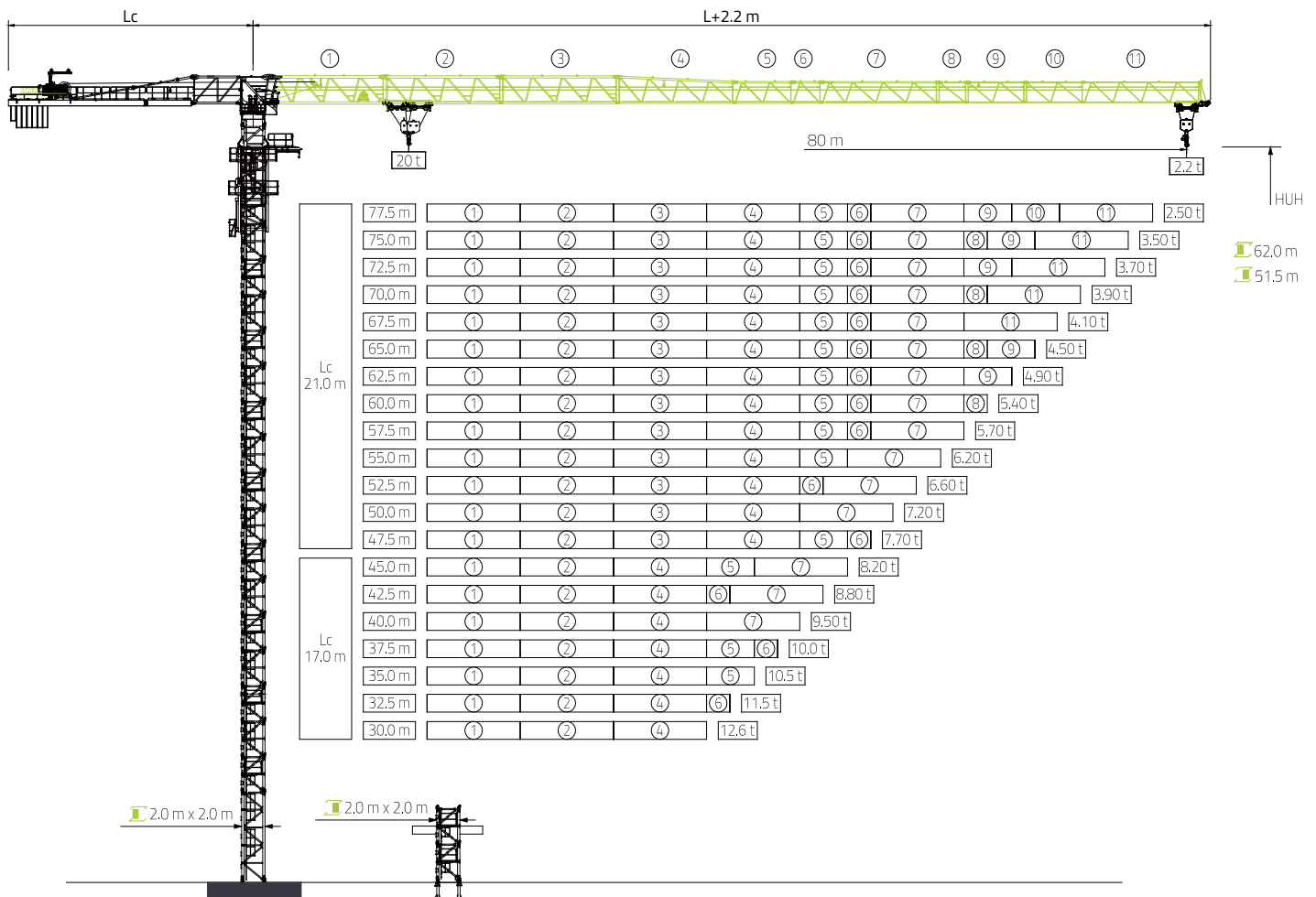

## 2.0 m Mast L69B For WA350-16T/20T

### Mast Reactions

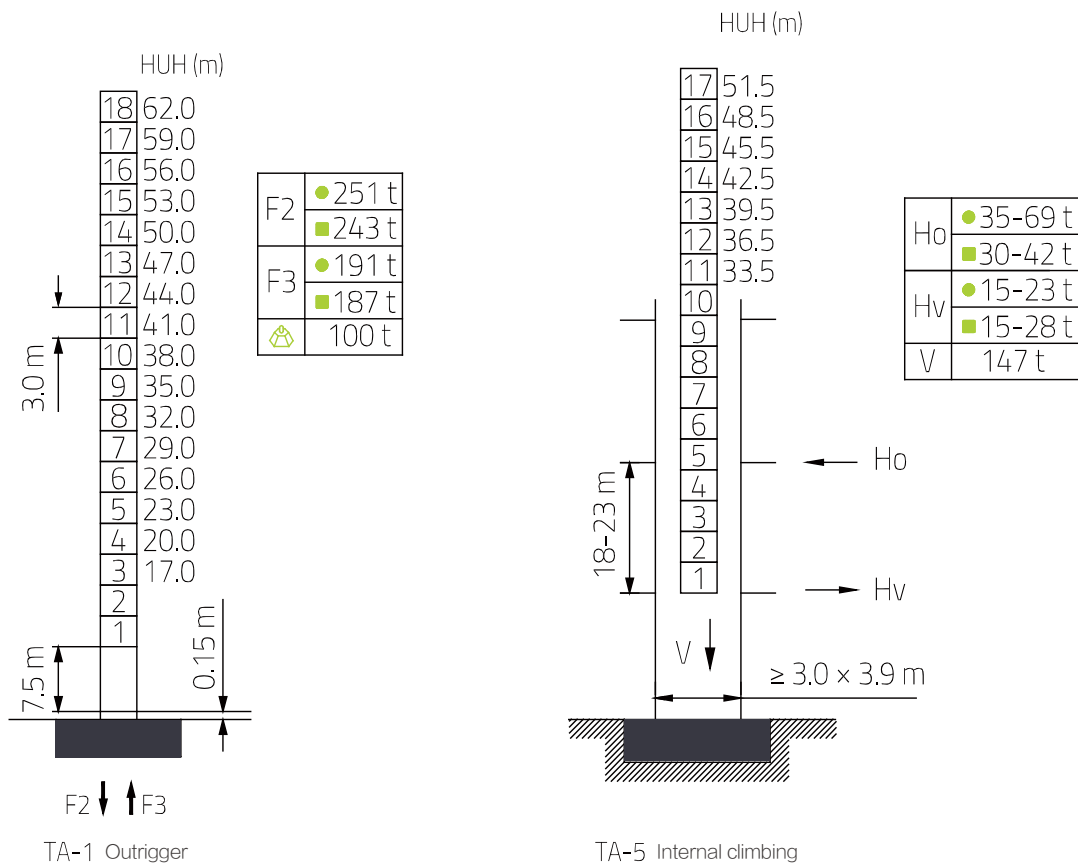

### Anchorage

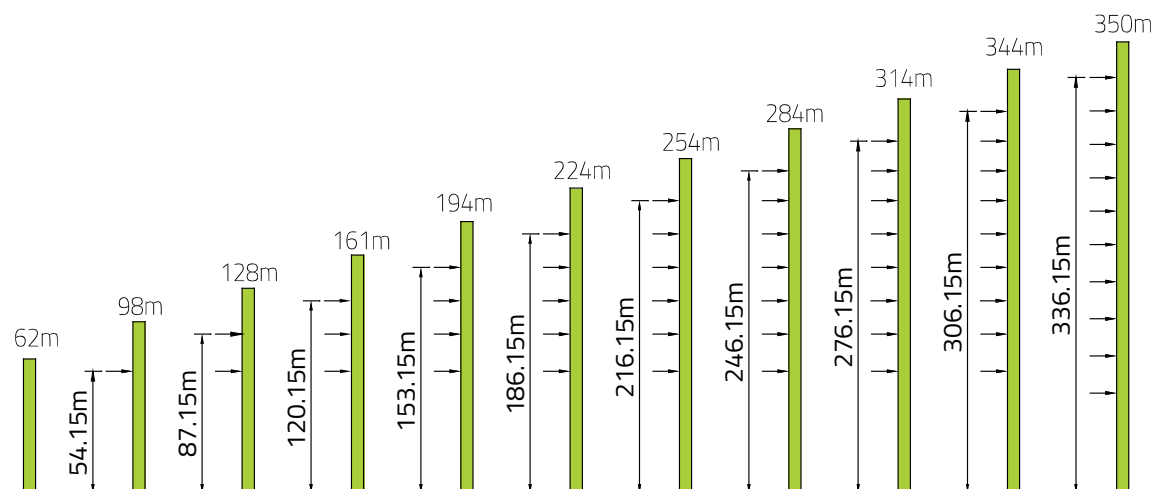





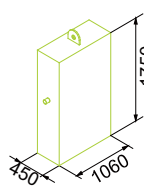
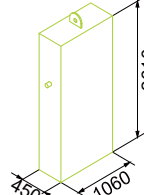
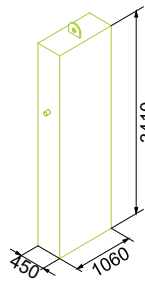

**Counter-jib Ballast & Ground Ballast**

	3.9 t	3.9 t	2.0 t	∅(t)	3.9 t	3.9 t	2.0 t	∅(t)	PHZ2000	PHZ3000	PHZ3900	Ground Ballast
	H55FL40-700				H75FL50-880							
800m	6	1	1	254	5	1	1	245				115.4 t
775m	6	1	1	254	5	1	1	245				
750m	6	0	0	264	6	0	1	254				
725m	6	1	1	254	5	1	1	245				
700m	5	1	1	245	6	0	0	234				
675m	6	0	0	234	5	1	0	225				
650m	5	1	1	245	6	0	0	234				
625m	6	0	0	234	5	1	0	225				
600m	6	0	0	234	5	1	0	225				
575m	5	0	0	225	5	0	1	215				
550m	5	1	1	215	4	1	1	206				
525m	4	1	1	206	5	0	0	195				
500m	5	0	0	195	4	1	0	186				
475m	5	0	0	195	4	1	0	186				
450m	6	0	0	234	5	1	0	225				
425m	5	1	1	215	4	1	1	206				
400m	4	1	1	206	5	0	0	195				
375m	4	1	1	206	5	0	0	195				
350m	5	0	0	195	4	1	0	186				
325m	4	0	0	186	4	0	1	176				
300m	4	1	1	176	3	1	1	167				

## Dimensions and Weights

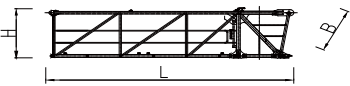
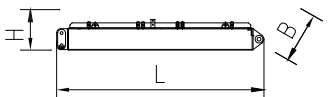
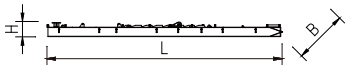
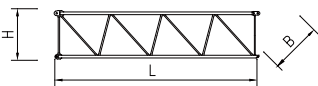
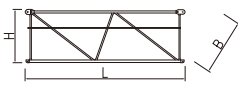
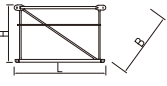
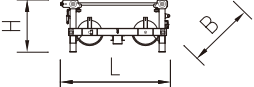
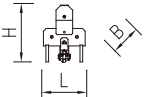
### Slewing crane parts



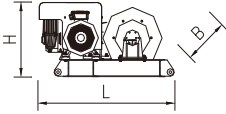
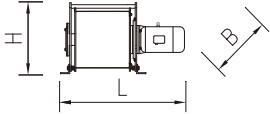
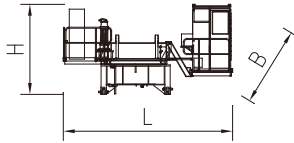

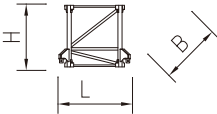
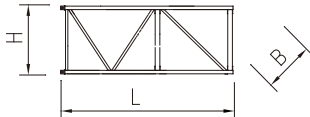
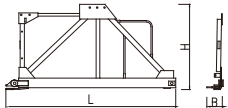
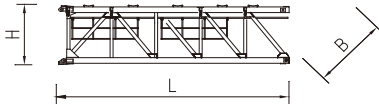

Slewing crane parts	Sketch		L (m)	B (m)	H (m)	Weight(kg ±5%)	
Counter-jib		Front	6.87	1.64	2.51	4450	
		Middle	4.20	1.58	0.66	1310	
		Rear	11.91	1.68	0.77	5700	
Jib section		G1	10.37	1.74	2.57	4480	
		G2	10.33	1.49	2.46	3450	
		G3	10.27	1.49	2.43	2780	
		G4	10.24	1.49	2.38	1950	
		G7	10.11	1.49	1.91	1320	
		G11	10.14	1.49	1.87	640	
		G5	5.20	1.49	1.94	900	
		G9	5.20	1.49	1.87	490	
		G10	5.20	1.49	1.87	380	
			G6	2.71	1.49	1.92	430
			G8	2.61	1.49	1.88	280
		Trolley		Main	2.17	1.71	0.93
Auxiliary	2.05			1.71	0.93	300	
Hook block			1.61	2.34	0.35	710	
Cabin			1.61	2.34	0.35	710	

Slewing crane parts	Sketch		L (m)	B (m)	H (m)	Weight(kg ±5%)
Hoisting mechanism		H55FL40 -700	2.78	2.04	1.21	3025
		H75FL50 -880	2.93	2.21	1.41	4375
Trolleying mechanism			1.36	0.92	0.76	660
Slewing assembly		2.0 m	5.61	2.82	3.00	9410

### Tower type L69

Crane tower parts	Sketch		L (m)	B (m)	H (m)	Weight(kg ±5%)
Connecting section		2.0 m	2.69	2.69	2.51	2130
Telescoping cage		2.0 m	7.25	2.67	2.67	4840
L69B1A (4 pieces)		2.0 m	3.50	2.12	0.70	1900
L69G20B-C		2.0 m	7.82	2.04	2.08	5120

## Mechanisms

			b d		b d		kW		
	H55FL40-700	t	2	8	4	16	55	700 m	
		m/min	90	36	45	18			
	H75FL50-880	t	2.5	10	5	20	75	880 m	
		m/min	95	38	47.5	19			
	S75CA-130.146LB14/12A S75CN-130.146LB14/12A	r/min	0-0.8				3×7.5		
	T75FC80-b(D)	m/min	0-115				7.5		
	ZAH52A-D×2 ZDH52A-D×2	m/min	0-25				4×5.2		
	380 V(±10%) 50Hz 380 V(±10%) 60Hz	H55FL40-700	85.0 kW (excluding travelling and climbing)						
	415 V(±10%) 50Hz 440 V(±10%) 60Hz	H75FL50-880	105.0 kW (excluding travelling and climbing)						

## EN

-  Reactions in service
-  Reactions out of service
-  Total weight
-  Counter weight
-  Ground ballast
-  Hoisting
-  Slewing
-  Trolleying
-  Travelling
-  Consult us
-  Fish plate pinned masts 2m
-  Counter-jib Length

## ES

- Reacciones en servicio
- Reacciones fuera de servicio
- Peso total
- Contrapesos
- Balasto en suelo
- Elevación
- Giro
- Traslación de carro
- Traslación de grúa
- Consulte con nosotros
- Mástil con planita y pernos para su ensamble 2m
- longitud de contrapluma

## RU

- Реакции в сервисе
- Реакции вне обслуживания
- Общий вес
- контргруз
- Наземный балласт
- Подъем
- Поворот
- Перемещение
- Передвижение
- Проконсультируйтесь с нами
- Соединенная болтами мачта 2m
- длина стрелы балансира



This document is non-contractual  
and subject to modification  
without prior notice

Este documento no es contractual  
y está sujeto a modificaciones sin  
previo aviso

Данный документ не является  
договорным и может быть  
изменен без предварительного  
уведомления