

# CRAWLER BULLDOZER ZD160-3



**ZOOMLION**

**Zoomlion Heavy Industry Science & Technology Co.,Ltd.**

Add:Zoomlion Overseas Building, No.613, 3rd Section, Furong Middle Road, Yuhua District, Changsha, Hunan, P.R.China 410205

Copyright © 2019 Zoomlion. All rights reserved. Reproduction and copying of any part of the Contents is not allowed for any purposes without Zoomlion's written approval.  
Note: No product coating appearance shall be subject to sample.



Printed in China VN: EN-EM-2019-09

**ZOOMLION**

## Features

The power system of ZD160 series bulldozer is equipped with Weichai WD10G178E25 turbocharged engine. With fuel consumption reduced by 20%-25%, it features high reliability, energy-saving performance, environmental protection and less noise. Working together with an advanced driveline, it provides advanced power matching and high rated power. Precise and reliable electronic monitoring system enables operators to know the equipment operation condition in real time. According to different working conditions and environments of bulldozers, working devices like straight tilt blade, U-blade, sanitation, angle blade and winch can be equipped. Falling object protective structure (FOPS) and roll-over protective structure (ROPS) are optional. In addition, air conditioning system, centralized lubrication system, engine cold start device and automatic track tensioning device are available to meet different users' demands. This bulldozer is widely used at the construction sites of energy, transportation, construction, municipal engineering, irrigation and water conservancy, and in the construction areas of mountains or forests.

ZD160 (L)-3 bulldozer for cold area is provided with intake preheater, engine with integrated fuel filtering, pumping and preheating unit, cab with double-glazed window, heater, large-capacity battery resistant to low temperature and seals of cold-resistant materials. It can work in -35°C low-temperature environment.

ZD160-3 bulldozer for hot area is equipped with air conditioning system and water tank specially designed for desert. The UV protective film for cab window and UV protective layer for hose are optional. It can work in about 50°C high-temperature environment.

ZD160S (H)-3 bulldozer is equipped with large-capacity R-blade. Boasting extremely high operation efficiency, it is specially developed to handle loose materials with lower shoveling density and larger individual volume.

ZD160TF-3 bulldozer is provided with semi-rigid suspension system and mechanical driveline. It is also equipped with a six-post roll-over protective structure (ROPS) and hydraulic or mechanical winch to satisfy the work requirements in forest exploitation areas.

ZD160T-3 bulldozer is the upgrade product of ZD160. It is provided with a semi-rigid suspension system and mechanical driveline. The mechanical driveline features high reliability, easy maintenance, high drive efficiency, low fuel consumption and high production efficiency.

ZD160TS (H)-3 is a mechanical swamp refuse bulldozer equipped with large-capacity R-blade specially designed for shoveling loose materials and swamp track shoes. It is an ideal device for landfilling and stacking operations at wasteyards.

ZD160TC (H)-3 is a brand new crawler-type mechanical swamp refuse bulldozer developed based on ZD160T-3. It is economical and highly reliable with tiny ground contact pressure. It can work on rather soft and muddy soil that normal bulldozers are unable to enter. Therefore, it is a necessity for special working conditions like tidal flats, swamps and bogs.

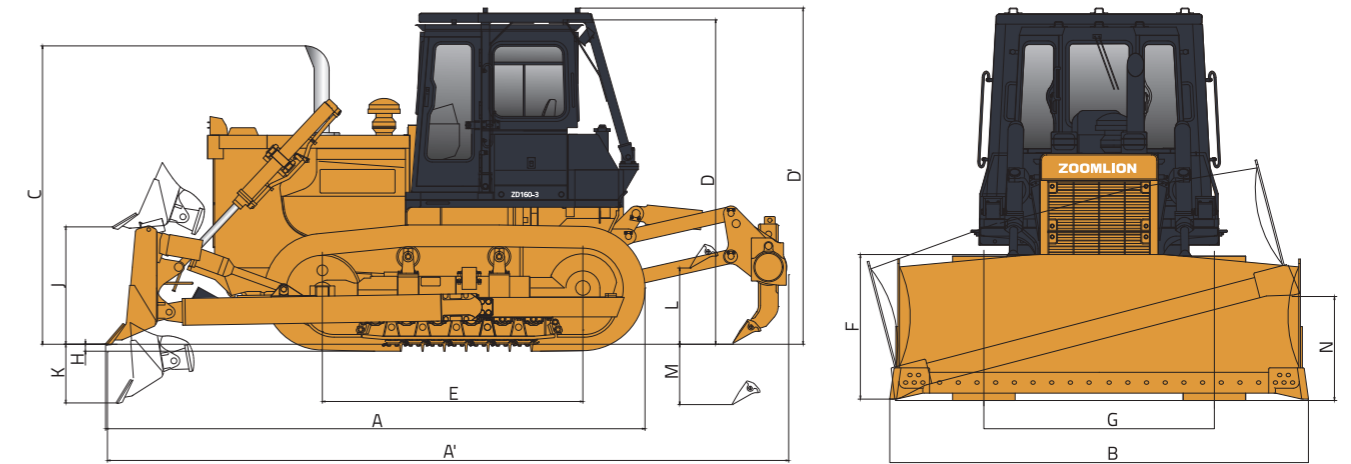

## Technical Parameters

	Item	ZD160-3/ ZD160(L)-3	ZD160S(H)-3	ZD160TF-3	ZD160T-3	ZD160TS(H)-3	ZD160TC(H)-3
Key technical parameters	Blade type	Straight Tilt Blade	Straight Tilt (Sanitation) Blade	Straight Tilt Blade	Straight Tilt Blade	Straight Tilt Blade	Straight Tilt Blade
	Working mass(kg)	16500	18100 (18355)	18090	15900	17500	19000
	Blade capacity(m³)	4.6	4.7 (10.4)	4.5	4.5	4.7 (10.4)	4.7
	Engine model	"Weichai WD10G178E25"	"Weichai WD10G178E25"	"Weichai WD10G178E25"	"Weichai WD10G178E25"	"Weichai WD10G178E25"	"Weichai WD10G178E25"
	Rated power/ Slewing speed (kW/rpm)	131/1850	131/1850	131/1850	131/1850	131/1850	131/1850
	Max. torque (N.m/rpm)	830/1100	830/1100	830/1100	830/1100	830/1100	830/1100
	Min. fuel consumption (g/kW.h)	215	215	215	215	215	215
	Max. Drawbar pull(kN)	152	152	152	152	152	152
	Ground pressure(kPa)	65.8	31	62.9	62.9	32.8	32.5
	Gradeability°	30	30	30	30	30	30
	Traveling speed of forward(km/h)	3.8/6.6/10.6	3.8/6.6/10.6	2.7/3.7/5.4/7.6/11	2.7/3.7/5.4/7.6/11	2.7/3.7/5.4/7.6/11	2.7/3.7/5.4/7.6/11
	Traveling speed of Reverse(km/h)	4.9/8.5/13.6	4.9/8.5/13.6	3.5/4.9/7.0/9.8	3.5/4.9/7.0/9.8	3.5/4.9/7.0/9.8	3.5/4.9/7.0/9.8

## Dimension And Operation Range

	Item	ZD160-3/ ZD160(L)-3	ZD160S(H)-3	ZD160TF-3	ZD160T-3	ZD160TS(H)-3	ZD160TC(H)-3
Basic technical parameters	A	Length (without multi-shank ripper) (mm)	5050	5305	5050	5050	5305
	A'	Length (with multi-shank ripper/winch) (mm)	6360	—	5662	6360	—
	B	Width(mm)	3416	4150	3416	3416	4150
	C	Height(mm)	2783	2892	2783	2783	2892
	D	Height of cab(mm)	3095	3140	3095	3095	3140
	D'	Height of ROPS(mm)	3200	3244	3200	3200	3244
	E	Ground contact length(mm)	2430	2935	2430	2430	2935
	F	Height of blade(mm)	1150	1595	1150	1150	1060
	G	Track gauge(mm)	1880	2300	1880	1880	2300
	H	Height of grouser(mm)	65	121	65	65	121
Operating range	I	Track shoe width(mm)	510	950	510	510	950
	J	Max. lift height of dozer(mm)	1095	1052	1095	1095	1052
	K	Max. drop depth(mm)	545	450	545	545	434
	L	Max. lift height of ripper(mm)	702	—	—	702	—
	M	Max. ripping depth of ripper(mm)	572	—	—	572	—
	N	Max. tilt(mm)	864	730	864	864	730