

CRAWLER BULLDOZER ZD220-3



ZOOMLION

Zoomlion Heavy Industry Science & Technology Co.,Ltd.

Add:Zoomlion Overseas Building, No.613, 3rd Section, Furong Middle Road, Yuhua District, Changsha, Hunan, P.R.China 410205

Copyright © 2019 Zoomlion. All rights reserved. Reproduction and copying of any part of the Contents is not allowed for any purposes without Zoomlion's written approval.
Note: No product coating appearance shall be subject to sample.



Printed in China VN: EN-EM-2019-09

ZOOMLION

Features

The power system of ZD220 series bulldozer is equipped with Cummins NT855-C280 (BC3) engine with a turbocharger, boasting globally perfect after-sales service system, high reliability, long life, low fuel consumption and less noise. Even if working on the highland of 3000m above sea level, it can ensure that the rated output power remains unchanged. Precise and reliable electronic monitoring system enables operators to know the equipment operation condition in real time. The machine features user-friendly design, comfortable operation and attractive appearance. According to different working conditions and environments of bulldozers, working devices like straight tilt blade, U-blade, R-blade, angle blade and winch can be equipped. Falling object protective structure (FOPS) and roll-over protective structure (ROPS) are optional. In addition, air conditioning system, centralized lubrication system, engine cold start device and automatic track tensioning device are available to meet different users' demands. This bulldozer is widely used in the earthwork constructions of building, roadbuilding, water conservancy, agriculture and national defense.

ZD220-3 bulldozer for hot area is equipped with air conditioning system and water tank specially designed for desert. Special ventilation and heat dissipation design is made for the engine protective cover. The UV protective film for cab window and UV protective layer for hose are optional. It can work in about 50 C high-temperature environment.

ZD220 (L)-3 bulldozer for cold area is provided with intake preheater, fuel hose and fuel filter heating jacket with heating function, cab with double-glazed window, heater, large-capacity battery resistant to low temperature and seals of cold-resistant materials. It can work in -35 C low-temperature environment.

ZD220S (H)-3 swamp bulldozer is provided with triangular track, featuring tiny ground contact pressure. It can be equipped with a large-capacity R-blade. It is suitable for working on soft soil, such as wetlands, swamps and landfills.

ZD220F-3 bulldozer for forest area is equipped with a six-post roll-over protective structure (ROPS) and hydraulic or mechanical winch. Working devices like extended ripper rack and straight tilt blade with guard bar are optional. It is suitable for working in forest exploitation areas.

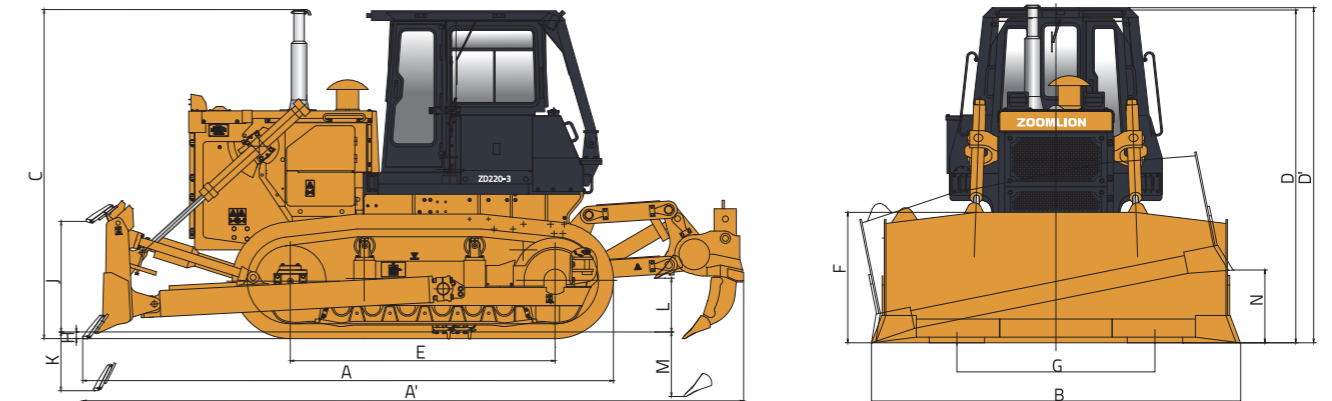

Technical Parameters

	Item	ZD220-3/ ZD220(L)-3	ZD220S(H)-3	ZD220F-3
Key technical parameters	Blade type	Straight Tilt Blade	Straight Tilt Blade	Straight Tilt Blade
	Working mass(kg)	23600	26050 (26300)	26436
	Blade capacity(m ³)	6.4	6.8 (13.5)	6.4
	Engine model	Cummins NT855-C280(BC3)	Cummins NT855-C280(BC3)	Cummins NT855-C280(BC3)
	Rated power/ Slewing speed (kW/rpm)	175/1800	175/1800	175/1800
	Max. torque (N.m/rpm)	1078/1250	1078/1250	1078/1250
	Min. fuel consumption (g/kW.h)	208	208	208
	Max. Drawbar pull(Kn)	207	230	207
	Ground pressure(kPa)	76	41	76
	Gradeability°	30	30	30
	Traveling speed of forward(km/h)	3.6/6.5/11.2	3.6/6.5/11.2	3.6/6.5/11.2
	Traveling speed of Reverse(km/h)	4.3/7.7/13.2	4.3/7.7/13.2	4.3/7.7/13.2

Dimension And Operation Range

	Item	ZD220-3/ ZD220(L)-3	ZD220S(H)-3	ZD220F-3	
Basic technical parameters	A	Length (without multi-shank ripper) (mm)	5460	5590	5460
	A'	Length (with single/multi-shank ripper) (mm)	7273/6811	—	5890(winch)
	B	Width(mm)	3725	4365	3725
	C	Height(mm)	3395	3435	3523
	D	Height of cab(mm)	3354	3435	3354
	D'	Height of ROPS(mm)	3395	3446	3523
	E	Ground contact length(mm)	2730	3480	2730
	F	Height of blade(mm)	1315	1271 (1971)	1315
	G	Track gauge(mm)	2000	2250	2000
	H	Height of grouser(mm)	72	123	72
Operating range	I	Track shoe width(mm)	560	910	560
	J	Max. lift height of dozer(mm)	1210	1300	1210
	K	Max. drop depth(mm)	538	550	538
	L	Max. lift height of ripper(mm)	538/555	—	—
	M	Max. ripping depth of ripper(mm)	666	—	—
	N	Max. tilt(mm)	735	500	735